



# Rigging System Design Guide

This design guide is intended to assist architects, facility owners, and users to plan rigging systems. While intended for high school, college, and community theatres, basic concepts covered are applicable to theatres of all sizes.

Why Do We Need Rigging? .....	2
How Much Rigging Do I Need?.....	2
Manual vs. Motorized Rigging.....	3
Is Rigging Safe? .....	5
Motorized Rigging .....	6
Selecting a Winch.....	6
Winch Types .....	7
Control Systems .....	10
Counterweight Rigging .....	11
Single or Double Purchase .....	12
Rope Lock Types .....	13
Arbor Guide Systems.....	14
Upright or Underhung Blocks .....	15
Structural Considerations .....	17
System Loads.....	17
Support Steel .....	17
Do I Need a Grid?.....	18
Loading Gallery.....	19
Rigging Equipment Locations.....	21
Rigging Safety .....	23

**The information in this document is being provided to help you design a functional, long lasting and safe rigging system. Much of the functionality and safety of an installed rigging system is dependent upon the proper selection and integration of equipment and on its proper installation and operation. For this reason, J.R. Clancy does not warrant the suitability of any product in this document for any application unless J.R. Clancy specifically designed and engineered the specifications and drawings of the rigging system and the products are installed in accordance with those documents.**

**The information in the document is current as of the printing date, and every effort has been made to ensure its accuracy. However, no guarantee of accuracy is made or implied. J.R. Clancy reserves the right to update its equipment designs at anytime.**

## ► WHY DO WE NEED RIGGING?

Rigging equipment is an essential part of most stages from the middle school level up to major performing arts centers. Rigging allows equipment on the stage to be raised and lowered, serving the following functions:

### **Access to Equipment**

The ability to raise and lower the stage lighting and other onstage equipment for adjustment, replacement of lamps and gels, and maintenance is essential. Lighting equipment is frequently moved to meet the requirements of individual productions. All of these functions are most easily performed when the battens are brought to the floor level, rather than working off of ladders.

### **Dramatic Effect**

For many theatres, the primary use of the rigging equipment is to move scenery for dramatic effect. A well-designed rigging system allows for simple, easy scene changes, and many shows require that scenery move in front of the audience. This adds drama and can be a key part of any production.

### **Masking of Equipment**

Curtains are used to mask equipment from audience view. In many cases the height of the masking curtains will need to change to meet the requirements of specific productions. The ability to raise and lower the curtains easily is important.

## **HOW MUCH RIGGING DO I NEED?**

The intended uses of the stage will help determine how much rigging is required. A middle school may only have a few sets to allow the lighting equipment to be raised and lowered for maintenance. A high school with an active drama program could have 20 - 40 rigging sets, while a performing arts high school could have more. Colleges and regional theatres may have similar requirements, while an active professional theatre can have 60 - 100 rigging sets.

Curtains may be dead hung (hung at a fixed height so that they cannot be raised or lowered) on simple stages. This limits their utility, as they cannot be raised or lowered to meet the needs of specific productions, or even raised to allow the stage floor to be swept.

Any stage where presentations will be made needs a few sets that can be used to raise and lower banners, signs, support hanging microphones, etc. If plays will be produced, additional rigging will be required to allow the movement of scenery and other dramatic effects. Rigging is all about technology aiding art, so it's hard to have too many sets.

## ▶ MANUAL VS. MOTORIZED RIGGING

Manually operated counterweight systems have been used in schools and theatres for over 80 years. The load being raised or lowered (scenery, curtains, or lights) is counterbalanced by an arbor loaded with the correct amount of steel weights, as shown below.

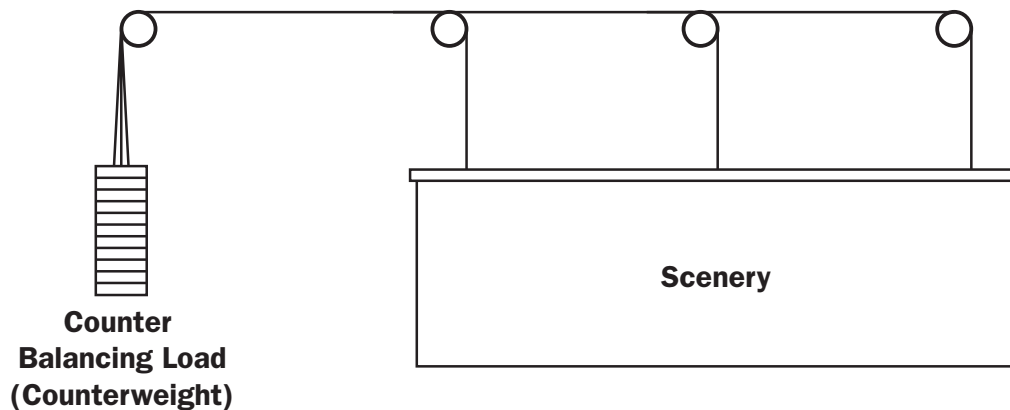

*Counter Balancing Load (counterweight)*

Manually operated, counterweighted sets are economical to purchase and install, and offer versatile performance capabilities. The operator can produce speeds that range from the subtle to the dramatic to meet the needs of the performance onstage. A trained operator can feel any change in the load or contact with an obstruction and take corrective action. Experienced operators can produce effects that go beyond technology, putting 'art' into the performance.

Operation of these sets depends on correctly balancing the load with steel weights. This requires that people using the equipment be trained in the correct procedures for operating the equipment.

Motorized rigging equipment is becoming more popular in new installations at all levels, from high schools to opera houses. The motorized rigging sets used onstage are generally “dead haul” sets, where the motor lifts the entire weight of the equipment without the use of counterweights. This eliminates the need for keeping sets balanced and the safety concerns that come with improperly balanced sets and the need to handle heavy weights. The sets are operated using control systems ranging from simple pushbutton panels to sophisticated computer systems with the ability to record and play back cues.

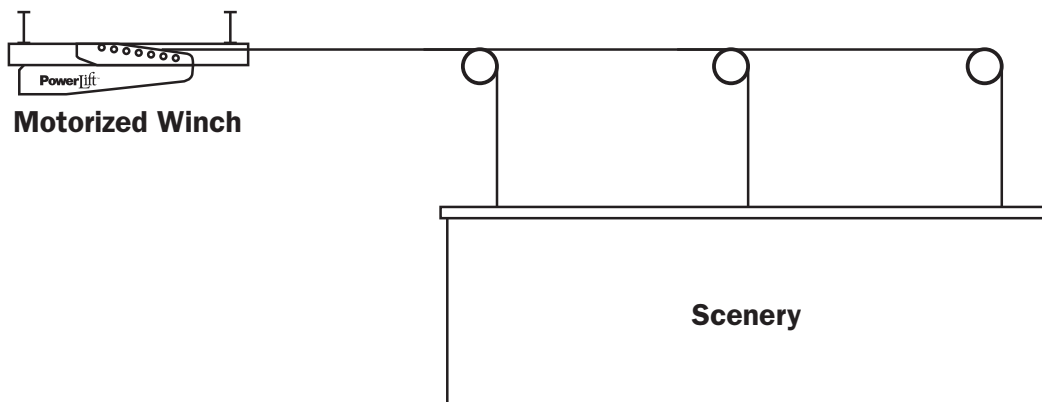

*Motorized Winch*

Motorized rigging sets have a higher initial cost than manually operated counterweight sets. However, recent advances in winch design and manufacturing have significantly reduced the costs of motorized rigging. (See page 7 for more information.)

Motorized sets are easier to use than counterweighted sets, and do not require the handling of counterweights. The ease of use does not reduce the need for operator training.



*PowerLift*

## **IS RIGGING SAFE?**

As with any type of machinery, there are dangers if the system is not used correctly. The students and staff must be trained in the proper use of the equipment, just as they are in technology, shop and art classes, or in science labs.

Operators must be particularly vigilant in watching the moving equipment. Counterweight equipment must be properly balanced, or the heavier load will descend. The greater the imbalance, the more rapid the descent.

While operating a manual set there is a great deal of tactile feedback that allows the operator to “feel” the load and its performance. This “feel” is missing from motorized equipment, and requires that the operators pay even more attention to the equipment they are controlling.

Throughout this guide we suggest ways of enhancing system safety during the design process.

## ► MOTORIZED RIGGING

Until recently, motorized rigging has been too costly for all but the largest theatres. Traditionally winches have been built to order in small quantities, resulting in high costs. In order to make motorized rigging affordable, we're starting to mass produce motorized winches that meet the needs of schools, colleges, local theatres, and many performing arts centers.

### **SELECTING A WINCH**

Motorized winches are available in a tremendous range of speeds, capacities, types, and costs. Our winches are designed and built to meet our customer's specific requirements. This section provides an overview of the major choices, types of winches, features, and options. Please contact us if you need additional information or assistance in selecting the equipment that will best meet your needs.

#### **Fixed Speed**

Fixed speed winches are generally used for heavy loads which do not have to move dynamically in front of an audience. Examples include lighting battens, speaker clusters, and orchestra shell ceilings.

Winch speeds vary widely with the application. An orchestra shell ceiling or lighting bridge may fly out at speeds as low as 3 feet per minute. Lighting sets typically fly at 20 - 30 fpm. Moving any faster with a fixed speed winch will result in stops and starts that may be too abrupt for lighting fixtures. However, a fixed speed curtain winch can often operate at 60 fpm without a problem.

#### **Variable Speed**

The tremendous range of speeds possible with variable speed winches makes them ideal for use with scenery that must move in front of the audience. A winch that performs a subtle move at rate of less than a foot per minute can suddenly travel at several hundred feet per minute in the next cue.

Top speeds are dictated primarily by the user's requirements. Scenery sets in college or regional theatres typically run at up to 120 or 180 fpm. Major performing arts centers and opera houses may have speeds of up to 240 fpm, while some of the newest international opera houses are using winches with speeds of up to 360 fpm. Main curtain hoists have been built to operate at even higher speeds.

Variable speed winches require solid state drives rated for hoisting duty, with the reliability and safety features necessary for use in a theatrical environment. Dynamic braking systems are also generally required on high-speed units. These factors make variable speed winches more costly than fixed speed winches.

#### **Capacity**

Traditionally, scenery sets have been rated to carry 15 - 20 lbs. per foot of batten length, while lighting sets are rated at 25 lbs. per foot for schools and performing arts centers, and up to 40 lbs. per foot for opera houses or Las Vegas style showrooms.

Most sets are dead haul, where the winch lifts the entire weight of the set. This is preferred for most scenery and general purpose applications. For sets with large fixed loads (over a few thousand pounds) the use of counterweight assisted winches should be used to reduce the size of the winch when possible.

## WINCH TYPES

### Drum Winch

The most widely used motorized winch has a single drum, long enough to accommodate all of the lift lines required for the set. The drum is helically grooved so that the lift lines wrap neatly in a single layer, to avoid damage to the wire rope and to keep all lines lifting evenly.

Winches can be located on the grid, galleries, or in a separate motor room. Head and loft blocks may be used to route the lift lines to the batten.

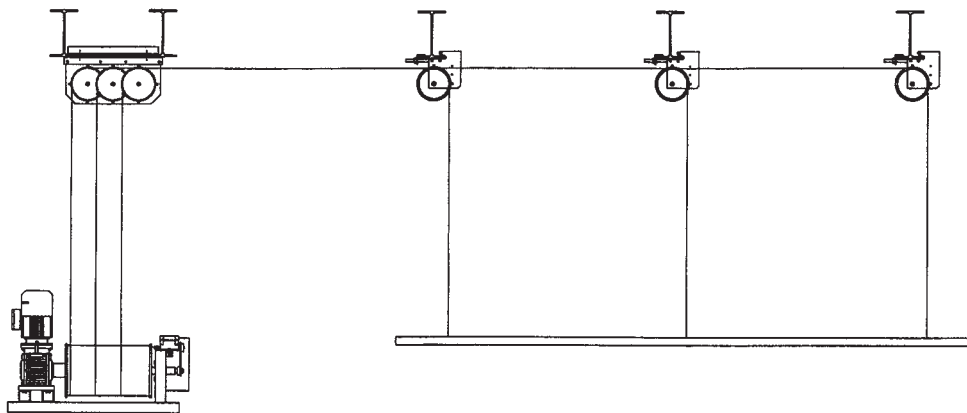

*Traditional Drum Winch*

### PowerLift™ Technology

The traditional drum winch shown above requires 10' between the drum and head blocks. A much more compact winch may be built using “moving drum” technology. In this type of winch the drum moves so that the point where the wire rope leaves the drum is always aligned with the head block. This allows the head block to be next to the drum, forming a compact, self-contained winch.

PowerLift™ winches use this technology to create compact, versatile units that can be used in new construction or renovations. PowerLifts are manufactured in standard speeds and capacities, selected to fulfill the needs of school, college and regional theatres.

By manufacturing the PowerLift in quantity, the cost per unit is significantly lower than the use of custom drum or line shaft winches. This makes motorized rigging affordable in facilities where it may not have been considered previously.

Several mounting configurations are shown below. The vertical wall mounting allows simple replacement of existing counterweight sets. The self-contained winches reduce installation time and costs.

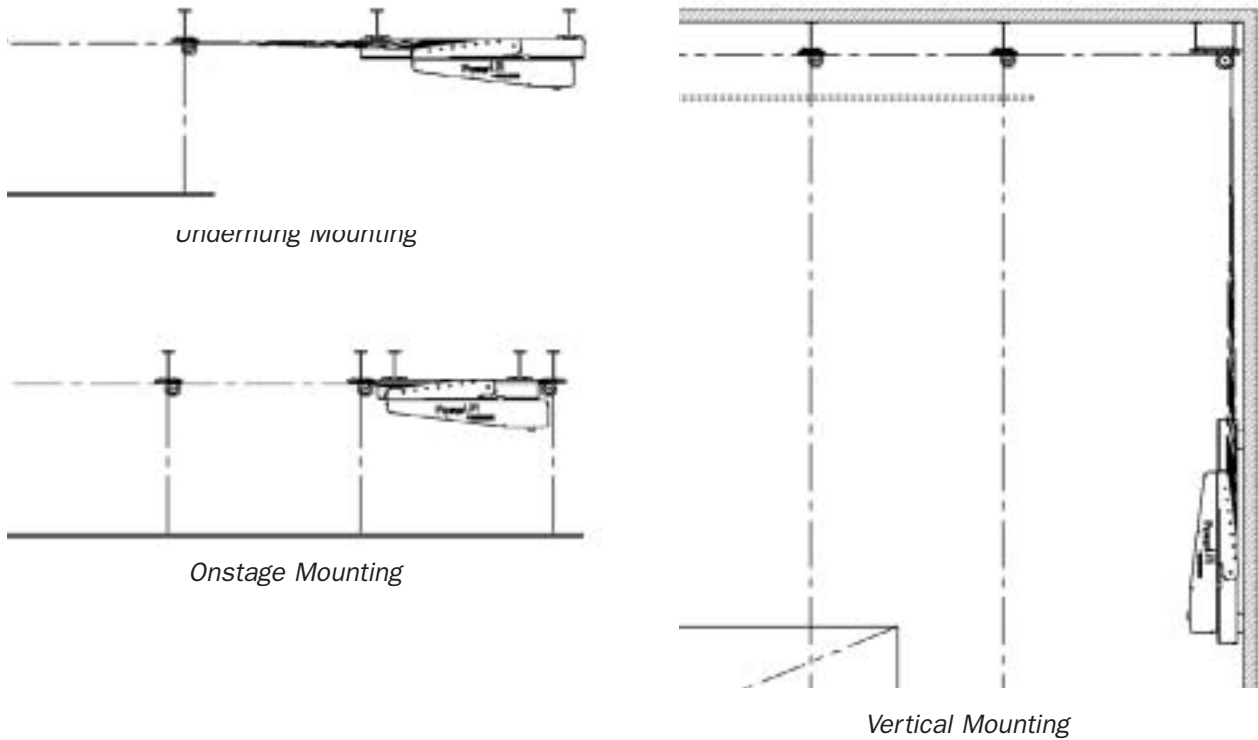

**PowerLift™**

The Clancy PowerLift winches use zero fleet angle technology to create compact, versatile units that can be used in new construction or renovations. These can be mounted in several configurations to best fit your facility. In many cases, they can replace existing counterweight sets.



*PowerLift Installation*

**More information and product specifications are available at [www.clancypowerlift.info](http://www.clancypowerlift.info).**



### Line Shaft Winch

Line shaft winches are self-contained units with a separate drum for each lift line. No wall or floor space is required for the winch, nor are head, loft, or mule blocks required. Due to its design, the load placed on the building structure is a vertical load only, without the resultant and compression loads normally associated with conventional rigging. Line shaft winches are particularly useful for renovations and in locations with limited space or limited structure.

In order to compensate for movements in the structural steel as loads change, line shaft winches should include universal joints in the shafting between the drums. This provides increased reliability, easier installation, and prevents the accumulation of destructive stresses within the shafting.

Line shaft winches offer convenience and simplicity, but are more expensive than drum winches.

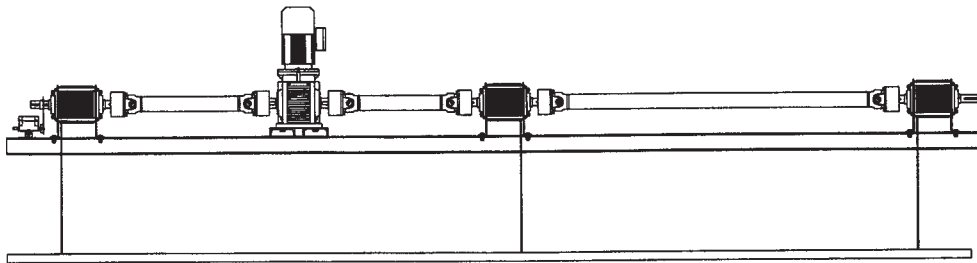

*Line Shaft Winch*

### Point Hoists

Point hoists offer the versatility provided by rope spot lines with the speed and capacity of a motorized set. The ultimate in flexibility, point hoists offer an individual winch for each lift line. Point hoists provide a versatility that is not available from rows of parallel battens.

Computerized rigging control consoles allow multiple winches to be synchronized, so that several point hoists can lift a single scenic piece. Or, the hoists can be taken out of synchronization to intentionally twist and tilt pieces for dramatic effect.

## CONTROL SYSTEMS

The simplest controls systems consist of manually operated Up / Down push buttons that allow positioning “by eye”. Clancy also offers several levels of SceneControl™ computerized controllers for more sophisticated programming.

All of the SceneControl systems feature color touch screen displays and allow the user to set speeds, target positions, and acceleration and deceleration rates. Larger systems allow the user to write and store cues for complete performances. Of course, all control components used in SceneControl systems are industrial grade, including the programmable logic controller.

When selecting rigging control systems, it’s important that no “home / office” grade components or computers are used to control motion. This would not be permitted on a factory production line, and certainly should not be allowed for overhead rigging. This is one of the most important things you can do to ensure a safe system.



*SceneControl*

## ► COUNTERWEIGHT RIGGING

Counterweight rigging systems consist of one or more rigging sets. These rigging sets should be installed on 6 or 8 inch centers from the stage side of the proscenium wall to within 3 or 4 feet of the back wall of the stagehouse for maximum versatility.

A simple, manual counterweight set consists of a balanced system of weights and pulleys by which loads such as scenery, curtains, or lighting equipment can be raised and lowered. Each set is comprised of a batten (1) suspended from lift line (2) which passes over loft block sheaves (3), then over a head block (4) at one side of the stage, and finally down to a counterweight arbor (5). The arbor holds weights that are adjusted by the user to balance (or counterweight) the load. Movement of the set is controlled by a rope hand line (6) that passes from the top of the arbor, over the head block, down through a rope lock (7) mounted on the locking rail (8), around a tensioning floor block (9) and back to the bottom of the arbor.

*Manual Counterweight Set*

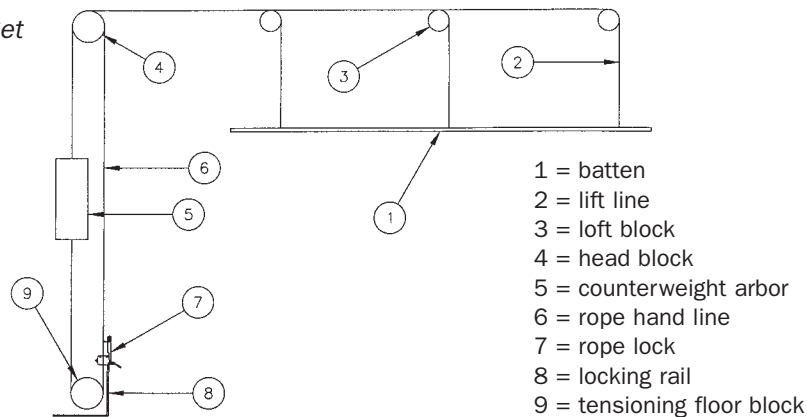

### **Balance is the Key**

The key to the system is to counter balance the load (scenery, lights, curtains) with weights, called the counterweight. A properly balanced system is inherently safe, as neither the load nor the counter balancing weight will move without an external force. The load can be moved with moderate effort by pulling on the hand line. This is the most popular type of rigging system used, in applications ranging from middle schools to opera houses.

It is essential that the operators be trained to fully understand the proper operation of the rigging equipment. The same requirements for training apply to motorized rigging equipment, and to many other types of equipment used in schools or theatres.

### **Counterweight Set**

There are several different ways counterweight rigging sets can be built. These depend on the manner in which the sets will be operated, how they are attached to the building, available space and stage height, and even whether they are to be powered by the operators or by some form of motorized assistance. Some of the decisions needed to make the best selections are discussed on the following pages.

## SINGLE OR DOUBLE PURCHASE

The weight and travel distance of the loaded batten equals the weight and travel distance of the properly loaded arbor in a single purchase counterweight set. These sets are simple to install and operate and are very efficient.

In buildings where space for vertical travel of the counterweight arbor is not sufficient for single purchase sets to operate, the counterweight side of the system can be double purchased. This creates a condition that requires twice the amount of weight in the arbor as is supported by the batten. However, only one foot of arbor travel is required for each two feet of batten travel. Double purchase systems are very useful in some situations, but they are more expensive and more difficult to install and operate. The additional mass and additional sheaves add both friction and inertia to the system making it harder to operate.

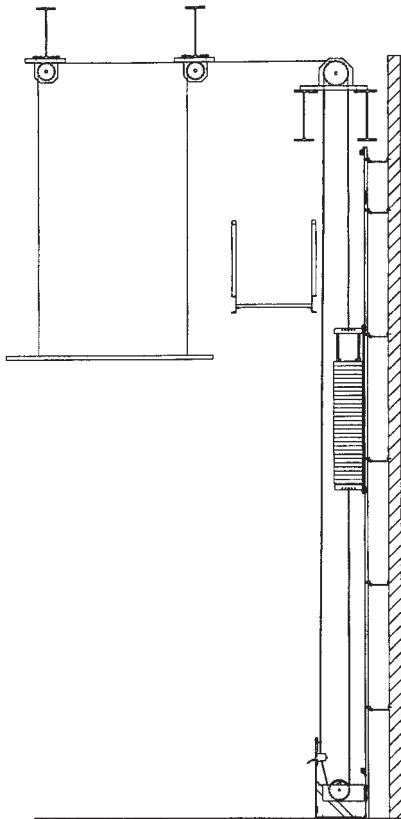

*Single Purchase Set*

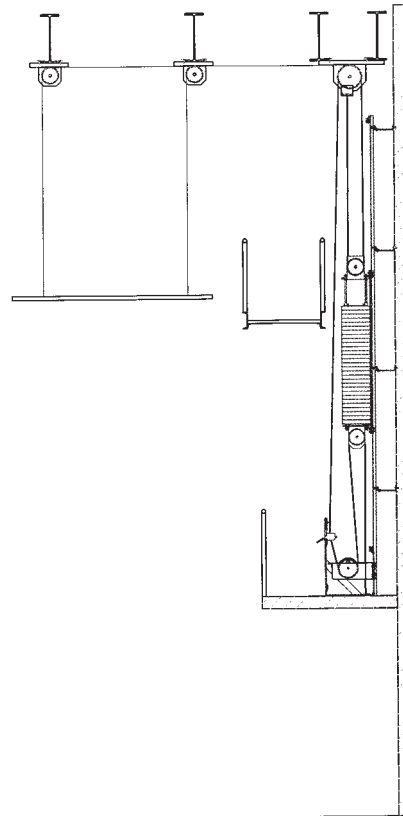

*Double Purchase Set*

## ROPE LOCK TYPES

The rope lock holds the hand line so that a properly balanced set will not move. Rope locks should provide for the use of a padlock to restrict operation by unauthorized personnel.

It is possible to have an imbalance between the load and counterbalancing weight if a set is improperly loaded. If a rope lock is opened on an out-of-balance set, the heavier load will move down. The greater the imbalance, the faster the movement. A runaway set can be dangerous. This is why it is essential that users are properly trained, and that untrained people must not use rigging equipment.

There are two types of rope locks, as shown below:



*Standard Rope Lock*



*SureLock*

The standard rope lock is widely used in theatres of all types, and is preferred in professional theatres.

The SureLock™ has a load detection mechanism that will not allow the lock to be opened if there is an out-of-balance condition of more than 50 lbs. This lock can help to prevent the inadvertent release of an unbalanced set and reduce the possibility of runaways. Many schools utilize load-sensing rope locks in order to provide an additional level of security beyond that provided by their training program. The use of SureLock™ rope locks adds less than 2% to the installed cost of a typical rigging system.

***More information and product specifications are available at [www.surelock.info](http://www.surelock.info).***

## ARBOR GUIDE SYSTEMS

Two methods of guiding the vertical travel of counterweight arbors are commonly employed. These are rigid guides (T-bar and J-guide) and wire guides. Lattice track guides are a third option that are only used in special applications due to the additional cost and the space required for each set.

Rigid guide systems are preferred for most installations. Slotted guides called “shoes” ride between equally spaced pairs of adjoining “T” or “J” shaped guide rails. Rigid guides are required for systems with travels that exceed 30 feet, on systems spaced closer than 8", and with all double purchase systems. They are also quieter than wire guides, and provide much better guiding.

Clancy offers two forms of rigid guides: For many years the standard has been steel T-Bar guides using a 1-1/2" x 1-1/2" x 3/16" steel T section. The new aluminum J-Guide has fewer parts than the T-Bar system and permits easier alignment. These guides are much easier to install, equally as strong and quieter in operation.

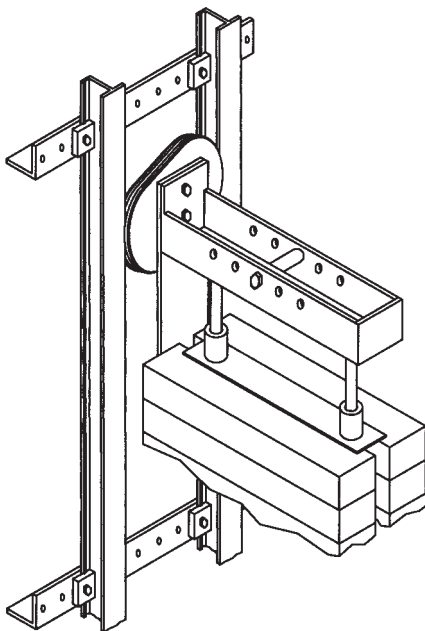

*J-Guide*

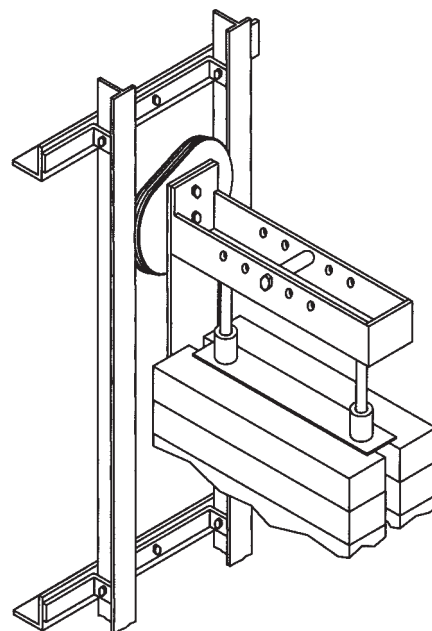

*T-Bar Guide*

The wire guide method uses a pair of slightly tensioned guide cables at each counterweight arbor. This guiding method is appropriate to small systems with capacities under 750 pounds, travel of less than 30 feet, and center distances between arbors of at least 8 inches. Wire guides can provide an economical alternative to rigid guide systems in less demanding applications. Care must be taken with these systems to provide structural capacity for the additional loads imposed upon the building by tension in the wire guides and to provide proper training for the maintenance of the wire guides.

## UPRIGHT OR UNDERHUNG BLOCKS

Structural designs, existing conditions, and operational preferences determine the choice of the block types. Upright rigging components are mounted on top of structural supports that are usually steel but may also be concrete or other materials. Underhung components attach to the bottom flanges of structural steel or other supporting members. Typical structural designs are shown below.

These basic styles are often combined in practice. One common combination uses the 55 series upright head block and 19 series underhung loft blocks. The gridiron is optional in this configuration and, if present, leaves it free for rigging spot lines, side masking, wrap around cycloramas, and other special effects. This configuration also provides the best access for maintenance and inspection and for making changes to the rigging layout.

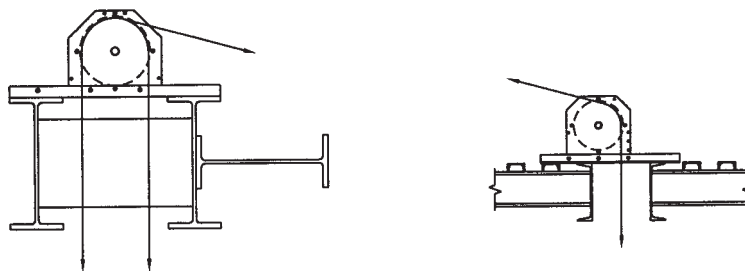

*Upright Head Block (Series 55) and Universal Loft Block*

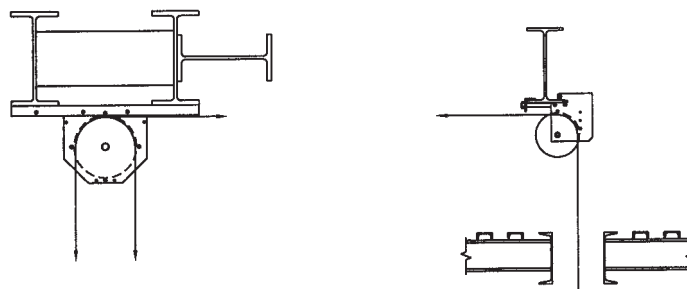

*Underhung Head Block (Series 59) and Underhung Loft Block (Series 19)*

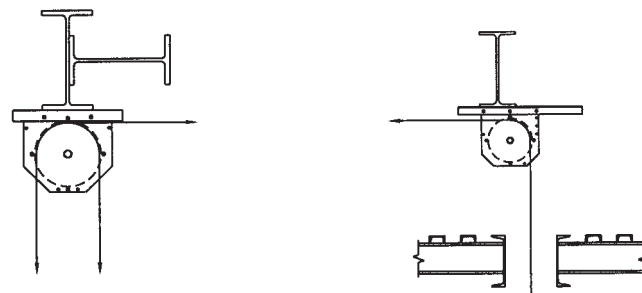

*Underhung Head Block (Series 59) and Universal Loft Block*

### Sheave Materials

Head block sheaves are available in cast iron or nylon. The nylon sheaves are lighter in weight, which reduces inertia and makes sets easier to operate. The lighter weight may also reduce installation time and cost. The load capacity of the head blocks are the same with either sheave material. There is little difference in price between the two materials.

Single line sheaves may be either cast iron or nylon. The majority of new installations use nylon sheaves, due to their light weight, low cost, and low inertia. Two, four, and eight line sheaves are also available. Loft blocks with nylon sheaves are approximately 20% lower in cost than those with cast iron sheaves.

### Idlers

Idler pulleys may be added to underhung loft blocks to carry the weight of the wire rope, reduce sag, and prevent rubbing against adjacent blocks. Assemblies contain three or six 3-1/2" diameter nylon sheaves on a 3/8" diameter shaft. The idler pulley assembly is mounted to the side of the block housing.

Idler pulleys cannot carry line loads or act as deflectors or mule blocks. When using idler pulleys, the loft block closest to the head block should be a multi-line block with grooves for all of the lift lines. This ensures that fleet angle and other alignment stresses are not transferred to the idler pulleys.



## ► STRUCTURAL CONSIDERATIONS

### SYSTEM LOADS

Counterweight systems impose unusual building loading conditions. Differing amounts of weight are balanced throughout the system which, in turn, impose equivalent horizontal loads on all rigging structures. The accompanying reaction diagrams use  $W$  to describe the maximum load capacity per batten, including the dead weight of the system, and  $L_n$  to designate the number of pickup cables in each set. Cables should be typically spaced at intervals of not more than 10 feet along the length of the batten. Greater spacing reduces the load carrying capacity of the batten or reinforced battens such as two pipe trusses. On average, scenery batten live loads are a maximum of 20 pounds per foot with electric batten loads being as much as 25 to 40 pounds per foot. Rigging sets for house curtains, fire curtains, orchestra shells, etc. must be calculated carefully and their live loads included in the total design of the system.

The dead weight of all equipment must also be included in the structural design criteria. The possibility of future expansion of the rigging system should also be considered.

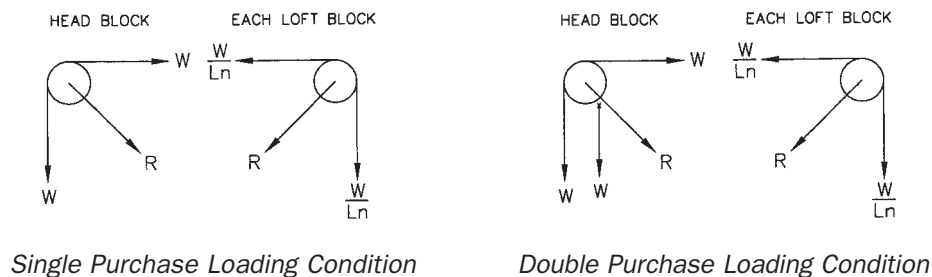

Single Purchase Loading Condition

Double Purchase Loading Condition

### SUPPORT STEEL

Head block beams may absorb several times the live load of the system. Horizontal bracing is often required on rigging steel. If cross bracing or diaphragms are used inside the head block beams, careful consideration must be given to their installation in order not to obstruct the cables that pass between the beams to the equally spaced head blocks above.

The following drawings provide examples of commonly used rigging steel configurations. Bar joists are not recommended for the support of loft blocks without considerable alteration for bracing. Tops of loft block well channels in gridirons (10" opening) should be flush with the top of the surrounding grid floor channels or bar grating to reduce tripping hazards.

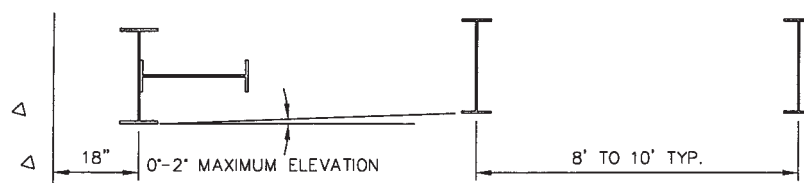

Recommended Underhung Steel Detail

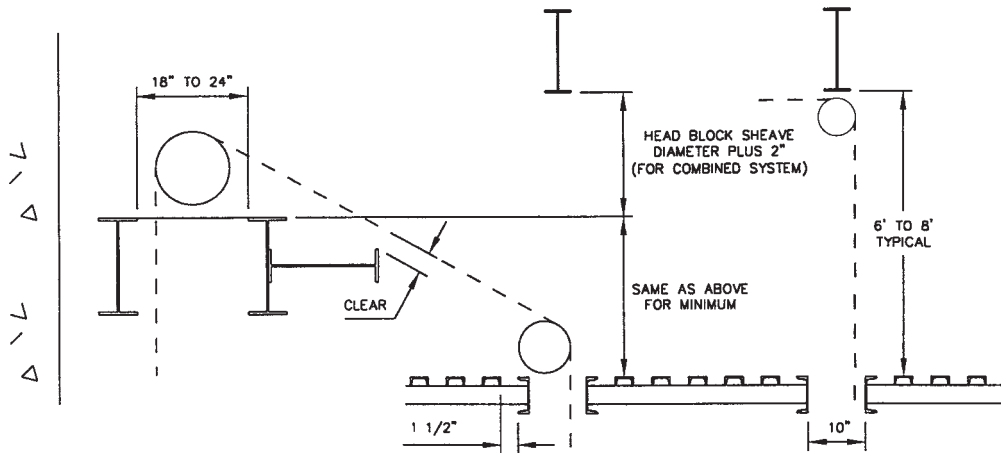

*Upright and Combination Mounting Steel*

**DO I NEED A GRID?**

A grid is a real convenience, as it allows access to all of the rigging equipment. It also provides a location for rigging spot lines, and other special rigging requirements. However, a grid adds height to the fly tower. For professional theatres a grid is a necessity. For other theatres, a grid is suggested if the theatre is being heavily used for productions with extensive rigging requirements. Many high school theatres will not require grids.

## LOADING GALLERY – An Essential Component

A loading gallery is a necessity for any counterweight rigging system. In order to properly balance (counterweight) the load on the batten, it is necessary to add or remove weight from the counterweight arbor. This must be done at the same time the weight is being changed on the batten, so that the system is always in balance.

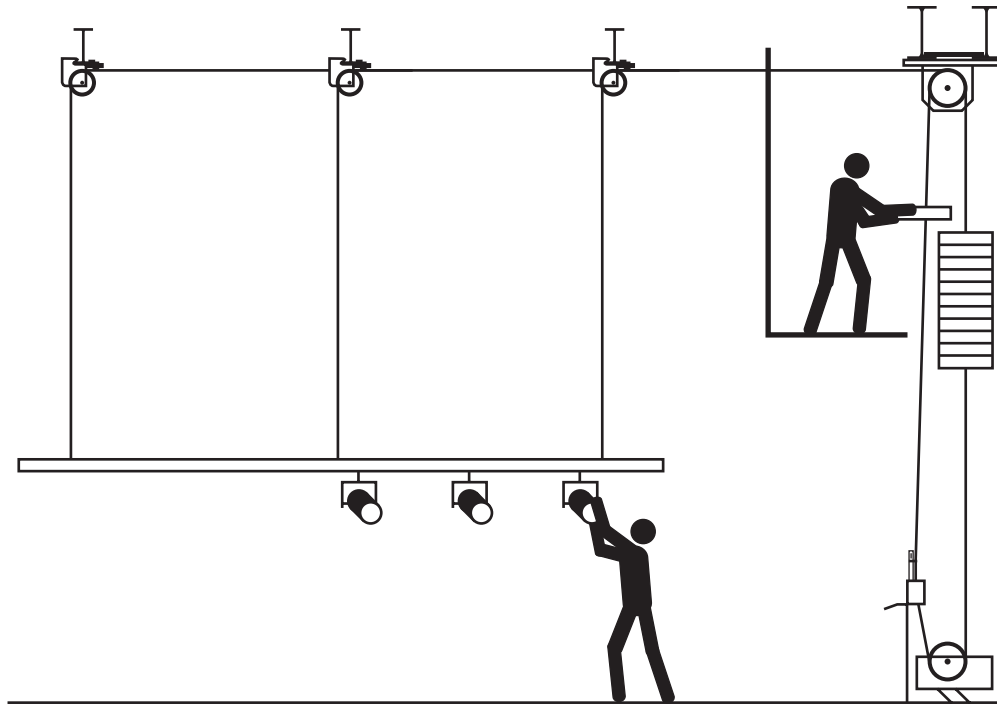

*After a load is added to the batten at the ground,  
weights are added to counter balance the load*

Loads are added to or removed from the batten when it is at floor level. When the batten is at floor level, the counterweight arbor is at its highest level. Therefore, it is essential to have a loading bridge so that there is access to the counterweight arbors to add or remove weights to balance the load. It may be necessary for people working on a loading bridge to use fall protection equipment.

Without a loading bridge it is necessary to raise and lower the battens in an out-of-balance condition. While there are procedures and equipment that can help in this situation, working with out-of-balance sets can be extremely dangerous, and should not be permitted. We do not recommend the provision of a counterweight rigging system without a loading bridge. **If a loading bridge cannot be provided, we recommend the use of motorized equipment in place of manual rigging.**

### Capstan Winch

If a loading bridge can't be provided or the system is existing, a capstan winch is required to safely load and unload battens. A capstan winch is a portable motorized unit that allows a counterweight arbor to be pulled down to the floor level to allow the counterbalancing weights to be added to or removed from an arbor.

A loading bridge is always the preferable approach. We do not recommend the use of capstan winches except in colleges with strong technical theatre training programs and professional theatres.

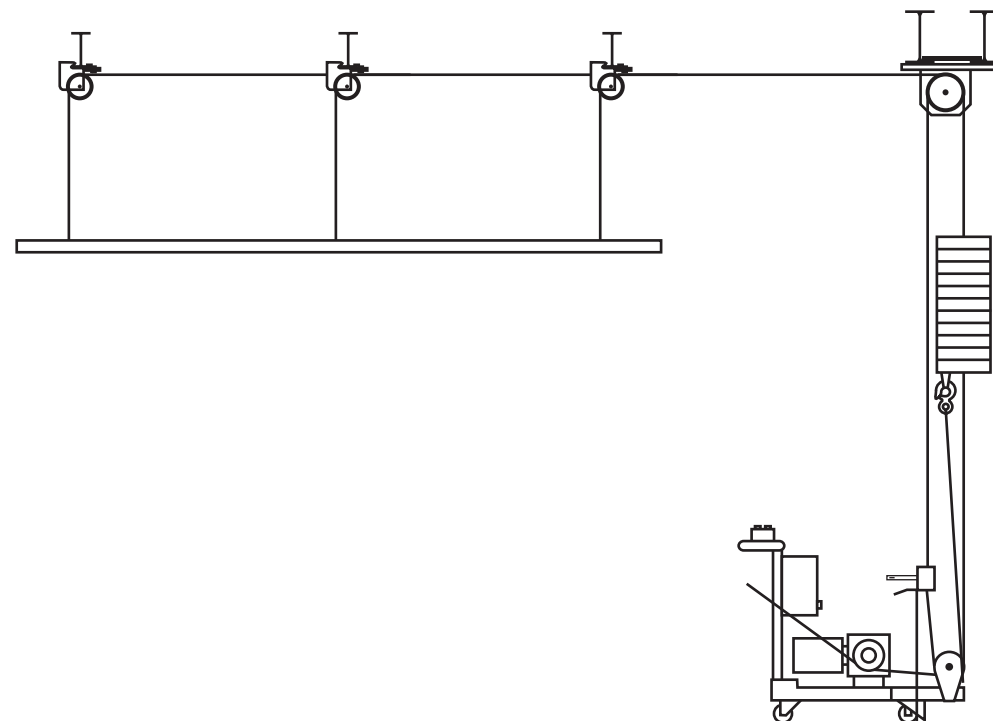

*Capstan Winch*

# ► RIGGING EQUIPMENT LOCATIONS

The following drawings show key dimensions used in laying out rigging equipment and support steel.

## Single Purchase Counterweight Set

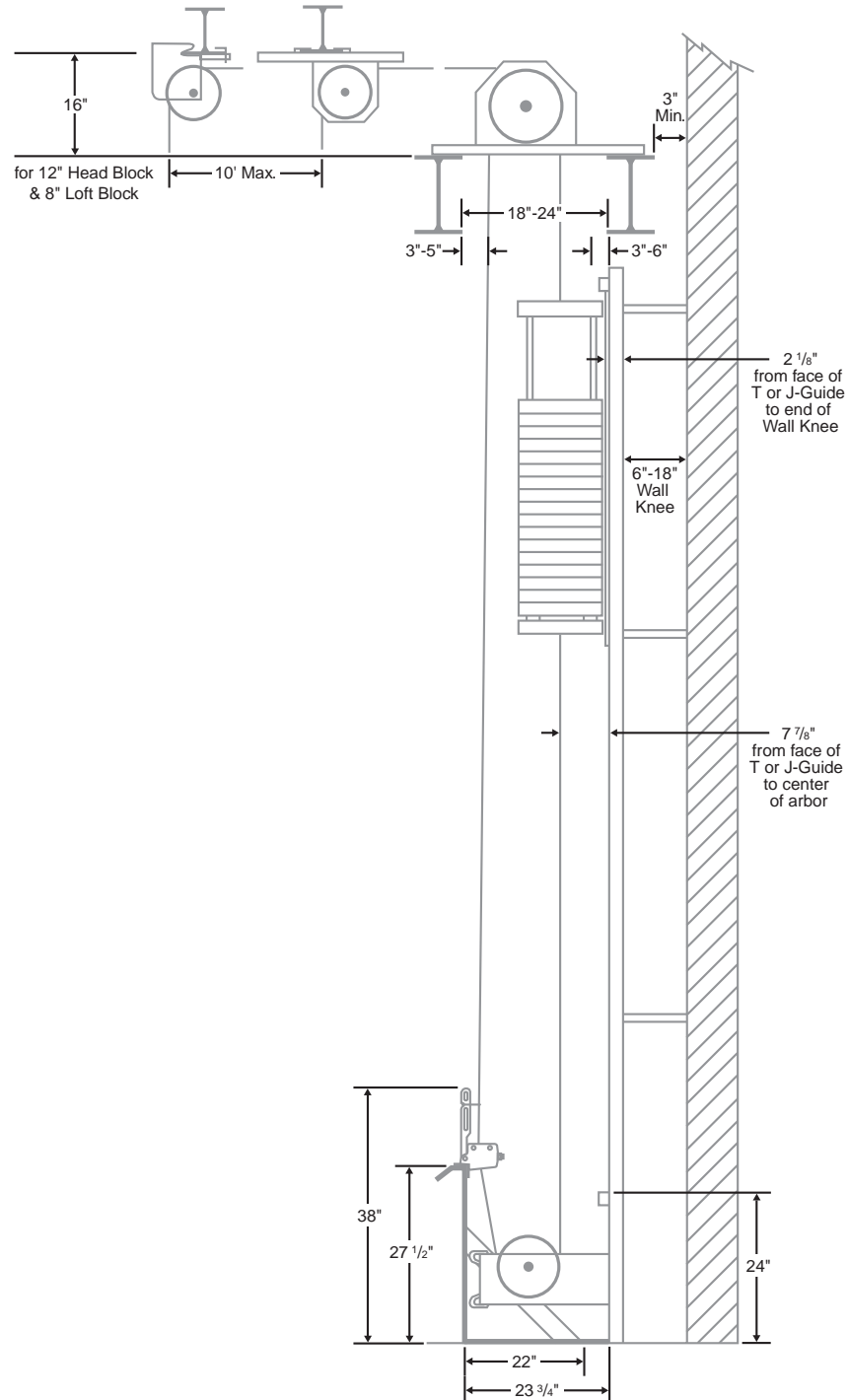

Loading Gallery Layout

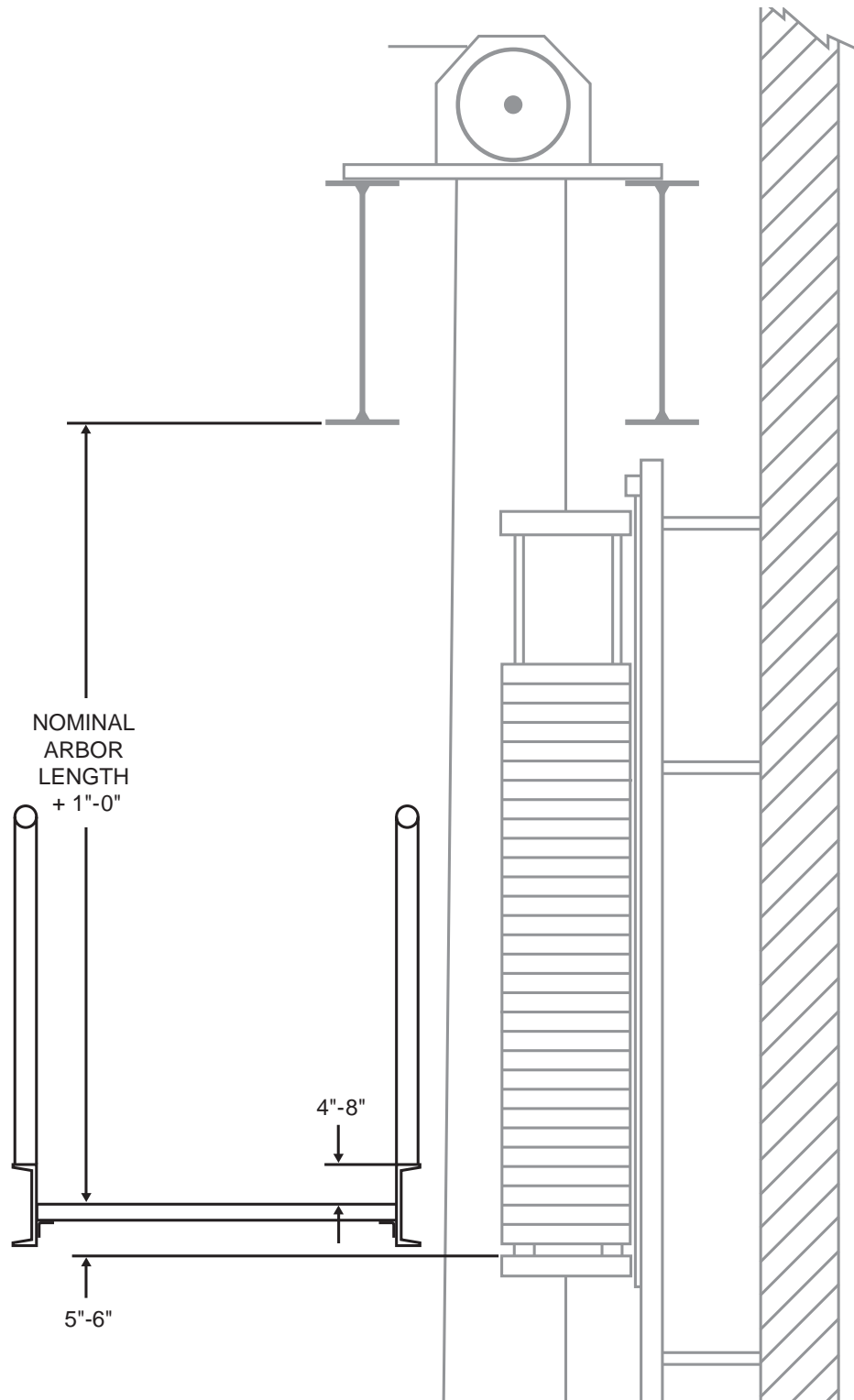

## ► RIGGING SAFETY

There are basic safety precautions that need to be followed with any piece of moving equipment. This is especially true with theatrical rigging, where heavy pieces may be moving close to people.

### **Training**

The key to any safety program is training. People who are using moving equipment must be properly trained to understand the equipment, the proper methods of operating equipment, and the hazards involved. Many facilities have formal training programs which must be completed before users are authorized to use equipment. We strongly encourage this and recommend a policy of allowing only trained and authorized personnel to use rigging equipment.

Operation manuals should be provided by your rigging supplier. Our operation manuals are also available on the Downloads page at [www.jrclancy.com](http://www.jrclancy.com). Other sources of rigging safety and operation information include: *Stage Rigging Handbook* by Jay Glerum, and *Stagecraft 1 - A Complete Guide to Backstage Work* by William H. Lord.

### **Inspection**

Rigging systems should be inspected annually by a competent person. Many theatrical dealers and installers offer inspection and maintenance services.

Users should also be aware of how their system performs. Any changes in the “feel” of the system or any unusual noises should be investigated.

### **Access**

As with any type of moving equipment, access to the rigging system should be restricted. All Clancy rope locks have a slot in the handle that allows the use of a user-supplied padlock to restrict the use of the set if further security is required.

## **WARNING!**

**The safe and efficient use of rigging equipment requires that the structural members supporting the equipment have adequate load-bearing capacity, that the equipment be properly selected, installed, tested and maintained, and that rigging system operators be properly trained. Failure to do any one of the foregoing may lead to equipment malfunction, which can cause serious injury or death. Should you have any questions regarding the selection of the proper equipment or installation or maintenance requirements, contact J.R. Clancy, Inc.**